

ES-37

Field Installation Manual

INDEX

Important Instructions.....	2
Product Specifications.....	3
Unpacking & Mounting	4
Connection Type 1	5- 6
Connection Diagram	7
Connection Type 2	8
Connection Type 3	9
Trouble Shooting For electrostatic sensitive area.....	10
Electrical Data Sheet	11
Recommended Part List.....	12

ES-37

IMPORTANT INSTRUCTIONS

ATTENTION: After completing the installation and testing, it is essential that this booklet is drawn to the attention of the person responsible for its future operation and maintenance and is available for ready reference all the time.

FAILURE TO READ AND FOLLOW ALL INSTRUCTIONS CAREFULLY BEFORE INSTALLATION & OPERATION WILL VOID WARRANTY OF ES-37 AND COULD CAUSE SERIOUS PERSONAL INJURY, FIRE HAZARD & ELECTRIC SHOCK MAY LEAD TO DEATH.

CAUTION:

To prevent electrical shock and/or equipment damage, disconnect electric power to system at main fuse or circuit breaker box until installation is complete.

PRECAUTION:

Does not use on circuits exceeding specified voltage.

Do not short main terminals to test.

Electrical Installation and all components of the system shall conform to Class II circuits as per the NEC code.



WARNING

Celec manufactured component parts that can be used in a wide variety of industrial & commercial applications. The selection and application of Celec products remains the responsibility of the equipment designer or end user. Celec accepts no responsibility for how its products may be incorporated into final design. Under no circumstances should any Celec product be incorporated into any product or design as the exclusive or sole safety control, all controls should be designed to dynamically fault defect and fail safety under all circumstances. Any warning provided by Celec must be passed through to the end user. Celec offers a warranty only as to the quality of its product to confirm to the catalog specifications. No other warranty is offered. Celec assumes no liability for any personal injury, property damage, losses or claims arising out of the misapplication and Non performance of its products.

PRODUCT SPECIFICATIONS



Model: **ES-37**
Rated Voltage:..... **415V AC**
Phases:..... **3**
Rated Frequency:..... **50Hz**
Maximum Current:..... **10 Amp per phase**
Rated KVAR **7**
Maximum Ambient Temperature Rating:..... **40°C**
Max Humidity **95% (Non Condensing)**
Electrostatic Sensitive Device (ESD Part) **Display**
Enclosure:..... **Type 1**

Terminal	Wire Size (AWG)	Connections Type	Torque (N-m)
T1	2.5 mm ² 600V	Terminal Block	1.2
T2	0.5 mm ² 600V	Terminal Block (Current Sensor)	0.4
Bonding Wire	6 mm ²	Earthing	8.5

UNPACKING

1. Un Pack the ES-37 from cartoon box packing using Plastic Strip Cutter.
2. Collect the Accessories as per the Packing Slip.
3. Remove any cardboard or thermocol packing inside the ES-37 given for support during transportation.
4. Do not use ES-37 in case of any Breakage or loose connections or Oil Spill inside.

MOUNTING

CAUTION: - Indoor Use Only, Type-1 Enclosure.

1. Choose the dry and Clean Wall to Install the ES-37 taking care conduit connections from bottom side. Enclosure Size is 400 x 300 x 120 mm and weight 11kg.
2. Premark the Mounting holes on wall or structure.
3. Make a Drill for the wall plugs.
4. Fix the Enclosure on wall with fasteners.

ES-37

Field Installation Manual

Connection Type # 1

Use this instruction

If 20 Amp circuit breaker is available in Main Breaker panel.

Power Connections

1. Remove Sub Panel cover exposing internal wiring and breakers. (Check Figure- 2)
2. Locate earth ground connection to panel grounding bar/or to earth ground terminal. Connect earth cable to main breaker panel earth ground rod. Use existing power cable connector for grounding cable. Ensure all mechanical connections are secure and making full contact.
3. Locate existing 3 Phase 20 Amp circuit Breaker.
 - A. Connect the Phase L1 from 20 Amp Breaker to Workbox.
 - B. Connect the Phase L2 from 20 Amp Breaker to Workbox.
 - C. Connect the Phase L3 from 20 Amp Breaker to Workbox.
4. Qualified Representative must inspect size of cable 2.5mm² from main breaker Panel L1 L2 and L3 to 20 Amp Breakers.
5. Connect power cables to Terminal Block of ES-37 as per items 1, 2, 3 above.

Current Sensor Connections

1. Install the split core sensor on the line side of main breaker Panel L1, L2 & L3 Phase.
2. Locate current sensor terminal block (S1, S2, S3, S4, S5 & S6).
3. Qualified Representative line side of Sub Panel connect 0.5mm²/ 1mm² Cable size of external current sensors.
4. Connect Junction Box to existing 1/2" conduit.
5. Firmly secure current sensor to line side (L1, L2 & L3) of main circuit breaker in sub panel or the main feeds if no main breaker existing.

Current sensor should be 0.333V only.

Correct Current Sensor install diagram below:

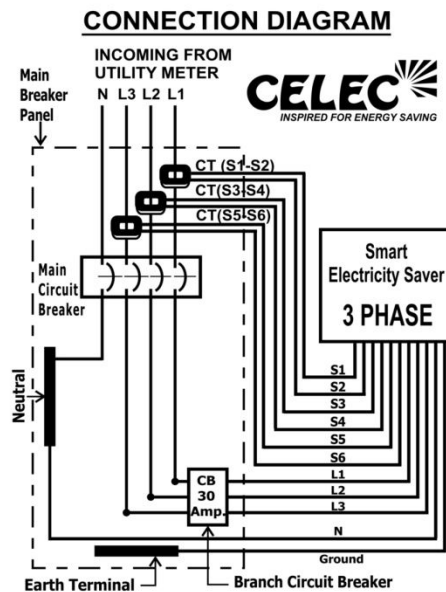

Important Instructions

- ▶ Install CTs before Main Circuit Breaker.
- ▶ Install CT (S1-S2) to the Phase L1
CT (S3-S4) to the Phase L2
CT (S5-S6) to the Phase L3
- ▶ Twist the CT wires to avoid Noise.
- ▶ Use 30 Amp. Branch Circuit Breaker.

www.celec.com

NOTE

All cables are attached to ES-37 unit install cables as per local codes and utilize approved IEEE standards and CE Certified components

Earth ground to be connected for ES-37 ground cable to Sub Panel earth ground rod.
All external connections and additional work must be performed by qualified representative in according to state and local codes.

All material used must confirm to the NEC and meet all applicable CE Certified.

Failure to comply will void warranty.

ES-37

Field Installation Manual

Connection Diagram

Current Sensor in accordance with NEC and all applicable codes.
All Mechanical connections shall be made using approved method.

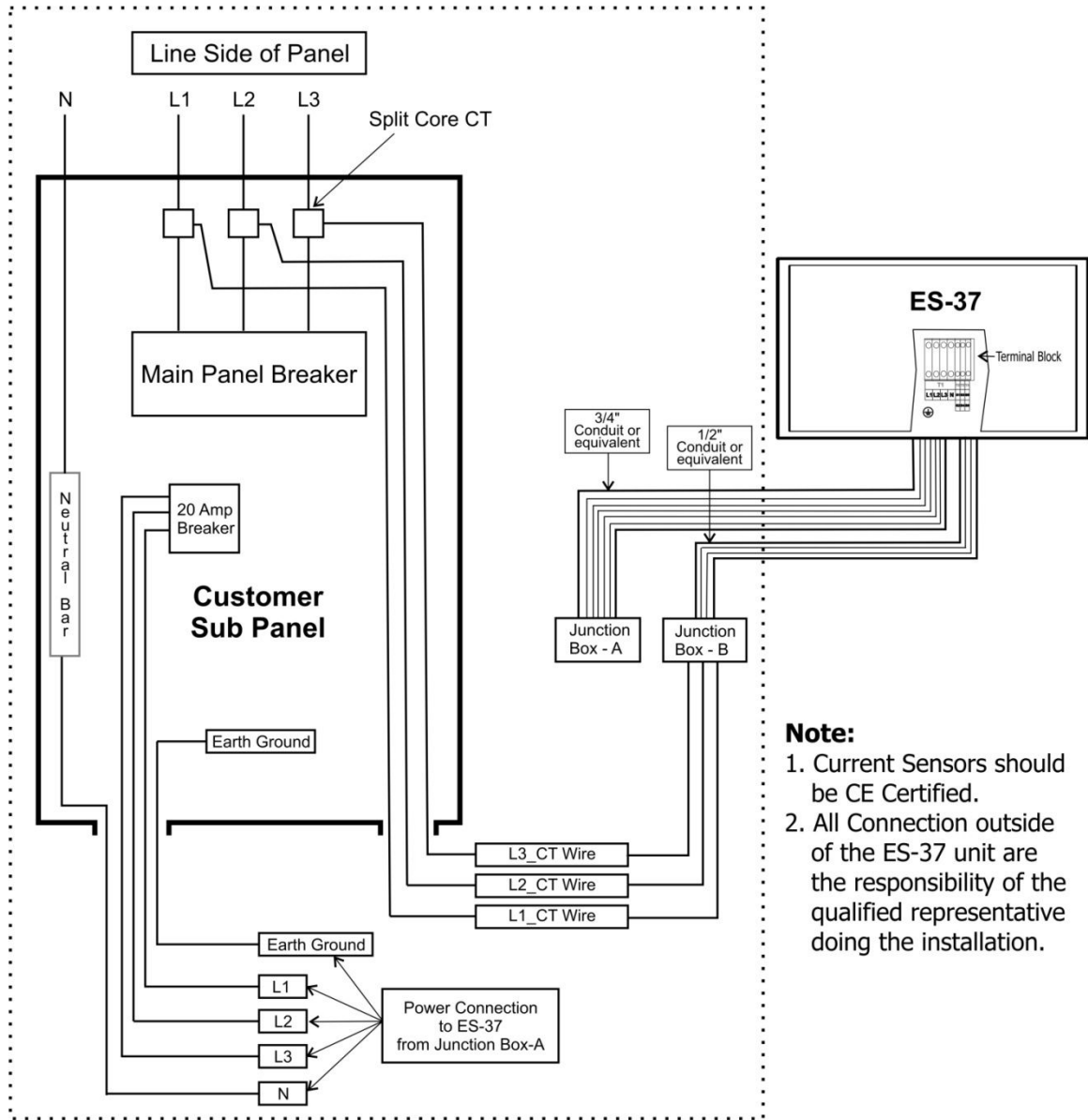

Figure-2

Note:

1. Current Sensors should be CE Certified.
2. All Connection outside of the ES-37 unit are the responsibility of the qualified representative doing the installation.

ES-37

Field Installation Manual

Connection Type#2

Use these instructions

If 20 Amp circuit breaker is unavailable, existing blanks are available.

ES-37 units should be mounted with four appropriate sized fasteners before connector to main breaker Panel.

1. Remove main breaker Panel covers exposing internal wiring and breakers. (Check Figure-2)
2. Remove existing 3/4 Pole breaker blanks and install new 3 Phase 20 Amp circuit Breakers.
 - A. Connect the Phase L1 from 20 Amp Breaker to Workbox.
 - B. Connect the Phase L2 from 20 Amp Breaker to Workbox.
 - C. Connect the Phase L3 from 20 Amp Breaker to Workbox
 - D. Connect to main breaker Panel Ground bar or Grounding Rood.
3. For rest of connection follow the Connection type#1 on page 5.

NOTE

All cables are attached to ES-37 unit install cables as per local codes and utilize approved IEEE standards and CE Certified components

Earth ground to be connected for ES-37 ground cable to Sub Panel earth ground rod.

All external connections and additional work must be performed by qualified representative in according to state and local codes.

All material used must confirm to the NEC and meet all applicable CE Certified.

Failure to comply will void warranty.

ES-37

Field Installation Manual

Connection Type#3

Use this instruction

If 20 Amp circuit breaker is unavailable and require a new disconnect switch or other approved device.

Representative must purchase 3 Phase, 20 Amp Blade-Fused Disconnect Switch or 20 Amp Circuit Breaker for connection of ES-37 to main breaker Panel.

1. Install new 3 Phase, 20 Amp Blade-Fused or Circuit Breaker external disconnect switch to wall or existing backboard. Qualified Representative should note if codes allow for direct connection to bus bars in sub panel or requires installation of an additional sub panel.
2. Wire in rigid conduit or equal between customer's sub panels, external disconnect switch and junction box. Connect to ES-37 using 3/4" conduit or equivalent.
3. Locate earth ground connection to panel grounding bar or to earth ground rod.
4. Locate 30" power cable. When installing the power cable do not use sensor connectors. Uses knock out at different location.
5. Connect ground earth cable from ES-37 unit to main breaker Panel earth ground rod. Use existing power cable connectors for grounding cable. Ensure all mechanical connector secure and making full contact.
6. For rest of connection follow the Connection type#1 on page 5.

NOTE

All cables are attached to ES-37 unit install cables as per local codes and utilize approved IEEE standards and CE Certified components.

Earth ground to be connected for ES-37 ground cable to Sub Panel earth ground rod.

All external connections and additional work must be performed by qualified representative in according to state and local codes.

All material used must confirm to the NEC and meet all applicable CE Certified.

Failure to comply will void warranty.

ES-37

Field Installation Manual

Trouble Shooting for Electrostatic Sensitive Area

How to Operate ESD Sensitive Display

LCD Display is sensitive to Damage / Misbehavior by electrostatic ESD use ESD precaution procedure while touching Display.

How to Recover Display from ESD Misbehavior/ Operation

In case of blurred Display or Misbehavior of Display.

1. Switch OFF the UNIT from mains.
2. Wait for 1 minute.
3. Switch ON the UNIT and Check for LCD Operation.

General Precaution

1. Use ESD Wipes to clean Display.
2. Do not touch Display during Overheating.
3. Do not handle static generating objects while working on Display.
4. Be sure to turn off the power and remove the power plug from all equipment before working on it.
5. Make sure you have a reliable ground point available near the work site.

ES-37

Field Installation Manual

Electrical Data Sheet

Model	ES-37
Phase Configuration	3 Phase 415 VAC
Maximum Line Voltage	440V AC
Rating	7 kVAr
Monitoring	PF,I,V,kVA, kVAr, KW & On status of capacitors
Accuracy	0.16 kVAr
Frequency	50Hz
Protection	External 3 Pole Circuit Breaker, Capacitor Inbuilt Protection P2
Lighting Strike	Circuit design with clearance and creep age distance/MOVs adequate MOVs not required.
Circuit breaker Required	20 Amp 3 Pole / 4 Pole
Low Losses	0.5 Watt per kVAr
Dissipation Factor	0.1% at 50 Hz and 25°C
Human Protection	All High voltage shielded from contact.
Operating temperature range	40°C Ambient
Max. Humidity	95% (Non Condensing)
Dimensions(L X H X D)	15.7" X11.8" X 7.8" Metal Enclosure
Operating Life	Switching tested up to 90,000 cycles
Wire Gauge & Rating	2.5 Sq mm, 600V
Unit Weight	11 kg

ES-37

Field Installation Manual

Recommended Parts List

	Qty.	Make	Part No.
1. 3/4" CE Certified Coupler between sub panel and ES-1 with work box.	2		
2. 1/2" CE Certified Coupler and appropriate junction box with seal –tight between sub panel and ES-1.	2		
3. Wire ties or approved straps for installation current sensor.	---		
4. Power Cables (30").	4		
5. Current Sensor split core 200 Amp/0.333V AC.	3		
6. 6mm ² Stranded copper ground cable.	1		
7. Fasteners screw for wall mounting ES-37	4		
8. 3 pole 20 Amp Breaker or Disconnect Switch for Type 2 & Type 3	1		

All the recommended parts supplied by qualified representative. Celec can provide the parts against order.

NOTE

1. Installation of materials and workmanship at the customer's sub panel shall be the responsibility of the qualified Representative in accordance with all state and local codes. Any and all connections exterior to the ES-37 unit shall be the responsibility of the qualified representative. 1
2. 3