

E-25

Field Installation Manual

INDEX

Important Instructions.....	2
Product Specifications.....	3
Unpacking & Mounting	4
Connection Type 1	5 – 6
Connection Diagram	7
Connection Type 2	8
Connection Type 3	9
Electrical Data Sheet	10
Recommended Part List.....	11

E-25

IMPORTANT INSTRUCTIONS

ATTENTION: After completing the installation and testing, it is essential that this booklet is drawn to the attention of the person responsible for its future operation and maintenance and is available for ready reference all the time.

FAILURE TO READ AND FOLLOW ALL INSTRUCTIONS CAREFULLY BEFORE INSTALLATION & OPERATION WILL VOID WARRANTY OF E-25 AND COULD CAUSE SERIOUS PERSONAL INJURY, FIRE HAZARD & ELECTRIC SHOCK MAY LEAD TO DEATH.

CAUTION:

To prevent electrical shock and/or equipment damage, disconnect electric power to system at main fuse or circuit breaker box until installation is complete.

PRECAUTION:

Does not use on circuits exceeding specified voltage.

Do not short main terminals to test.

Electrical Installation and all components of the system shall conform to Class II circuits as per the NEC code.



WARNING

Manufactured component parts that can be used in a wide variety of industrial & commercial applications. The selection and application of products remains the responsibility of the equipment designer or end user. Manufactured accepts no responsibility for how its products may be incorporated into final design. Under no circumstances should any product be incorporated into any product or design as the exclusive or sole safety control, all controls should be designed to dynamically fault defect and fail safety under all circumstances. Any warning provided by Manufactured must be passed through to the end user. Manufactured offers a warranty only as to the quality of its product to conform to the catalog specifications. No other warranty is offered. Manufactured assumes no liability for any personal injury, property damage, losses or claims arising out of the misapplication and Non performance of its products.

PRODUCT SPECIFICATIONS



Model:	E-25
Rated Voltage	440V AC
Phases	3
Rated Frequency	50Hz
Maximum Current each phase	34 Amp
Rated kVar	25
Maximum Ambient Temperature Rating	40°C
Max Humidity	95% (Non Conditioning)
Pollution Degree	2

Terminals	Wire Size (mm)	Connection Type	Torque (N-m)
T1	10 mm ² , 600V	Load Breaker Switch	2
T2	1 mm ² , 600V	Terminal Block (Current Sensor)	0.4
Bonding Wire	10 mm ²	Earthing	15

UNPACKING

1. Un Pack the E-25 from cartoon box & safety wooden packing using Plastic Strip Cutter & Spanner of BSW-17.
2. Collect the Accessories as per the Packing Slip.
3. Remove any cardboard or thermocol packing inside the E-25 given for support during transportation.
4. Do not use E-25 in case of any Breakage or loose connections or Oil Spill inside.

MOUNTING

CAUTION: - Indoor Use Only, Type-1 Enclosure.

1. Choose the dry and Clean Wall to Install the E-25 taking care conduit connections from Top Right
Panel Size is 500 x 500 x 210 mm and weight 28 Kg.
2. Premark the Mounting holes on wall or structure.
3. Make a Drill of 10mm up to the depth of 50mm for the wall plugs provided as Accessories.
4. Hang the Panel on wall plugs.
5. Fix the central Pin of wall plug with hammer before tighten the wall plugs.

E-25

Field Installation Manual

Connection Type # 1

Use this instruction

If 60 Amp circuit breaker is available in customer sub panel.

E-25 unit is designed for use with Customer Sub Panel-operating at 440V AC Connection, 100 to 400 Amp.

Power Connections

1. Remove Sub Panel cover exposing internal wiring and breakers. (Check Figure- 2)
2. Locate earth ground connection to panel grounding bar/or to earth ground terminal. Connect earth cable to customer sub panel earth ground rod. Use existing power cable connector for grounding cable. Ensure all mechanical connections are secure and making full contact.
3. Locate existing 3- ϕ , 60Amp circuit Breaker.
 - A. Connect the Phase L1 from 60 Amp Breaker to Workbox.
 - B. Connect the Phase L2 from 60 Amp Breaker to Workbox.
 - C. Connect the Phase L3 from 60 Amp Breaker to Workbox.
4. Qualified Representative must inspect size of cable 10mm² from Customer Sub Panel L1, L2, and L3 to 60 Amp Breakers.
5. Connect power cables to load breaker switch of E-25 as per items 1, 2, 3 above.

Current Sensor Connections

1. Install the one split core sensor on the line side of Customer Sub Panel L3 Phase.
2. Locate current sensor terminal block (S1, S2).
3. Qualified Representative line side of Sub Panel connect to 1mm² Cable size of external current sensors.
4. Connect Junction Box to existing 1/2" conduit.
5. Firmly secure current sensor to line side (L3) of main circuit breaker in sub panel or the main feeds if no main breaker existing.

Current sensor 0.333V should be CE approved only.

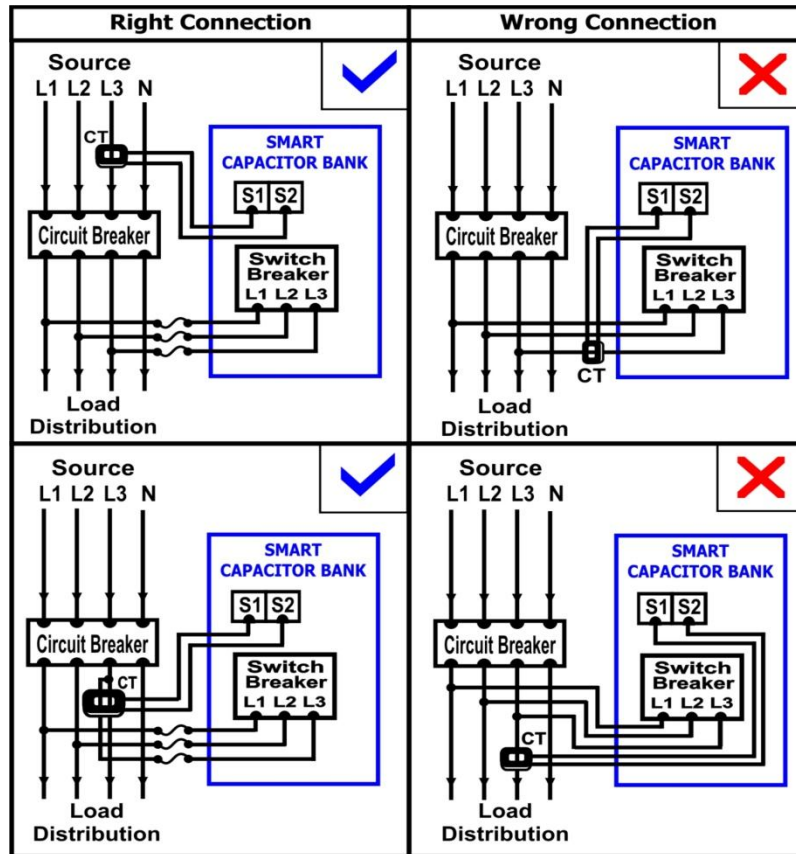

Figure-1

NOTE

All cables are attached to E-25 unit install cables as per local codes and utilize approved IEEE standards.

Earth ground to be connected for E-25 ground cable to Sub Panel earth ground rod.
All external connections and additional work must be performed by qualified representative in according to state and local codes.

All material used must confirm to the NEC and meet all applicable.

E-25

Field Installation Manual

Connection Diagram

Current Sensor in accordance with NEC and all applicable codes.
All Mechanical connections shall be made using approved method.

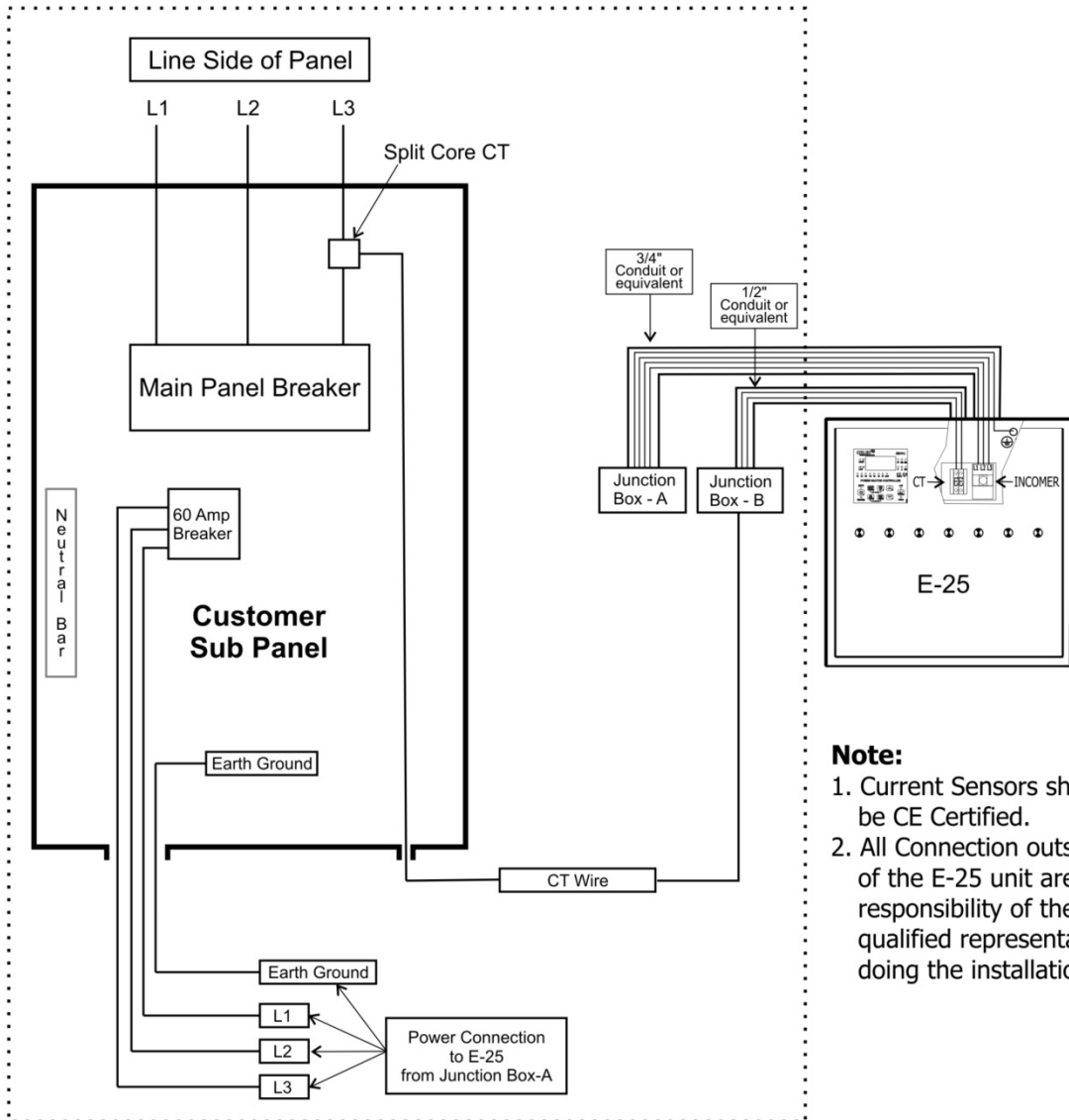

Note:

1. Current Sensors should be CE Certified.
2. All Connection outside of the E-25 unit are the responsibility of the qualified representative doing the installation.

Figure-2

E-25

Field Installation Manual

Connection Type#2

Use these instructions

If 60 Amp circuit breaker is unavailable, existing blanks are available.

E-25 unit is designed for use with Customer Sub Panel-operating at 415/440 VAC Delta Connection, 100 to 400 Amp.

E-25 units should be mounted with four appropriate sized fasteners before connector to customer Sub Panel.

1. Remove Sub Panel covers exposing internal wiring and breakers. (Check Figure-2)
2. Remove existing 3- ϕ breaker blanks and install new 3- ϕ 60 Amp circuit Breakers.
 - A. Connect the Phase L1 from 60 Amp Breaker to Workbox.
 - B. Connect the Phase L2 from 60 Amp Breaker to Workbox.
 - C. Connect the Phase L3 from 60 Amp Breaker to Workbox.
 - D. Connect to Customer Sub Panel Ground bar or Grounding Rod.
3. For rest of connection follow the Connection type#1 on page 5.

NOTE

All cables are attached to E-25 unit install cables as per local codes and utilize approved IEEE standards and CE Certified components

Earth ground to be connected for E-25 ground cable to Sub Panel earth ground rod.

All external connections and additional work must be performed by qualified representative in according to state and local codes.

All material used must confirm to the NEC and meet all applicable CE Certified.

Failure to comply will void warranty.

E-25

Field Installation Manual

Connection Type#3

Use this instruction

If 60 Amp circuit breaker is unavailable and require a new disconnect switch or other approved device.

Customer Sub Panel- 415/440 VAC Connections, 100 to 400 Amp.

Representative must purchase 3- ϕ , 60 Amp Blade-Fused Disconnect Switch or 60Amp Circuit Breaker for connection of E-25 to Customer Sub Panel.

1. Install new 3- ϕ , 60 Amp Blade-Fused or Circuit Breaker external disconnect switch to wall or existing backboard. Qualified Representative should note if codes allow for direct connection to bus bars in sub panel or requires installation of an additional sub panel.
2. Wire in rigid conduit or equal between customer's sub panels, external disconnect switch and junction box. Connect to E-25 using 3/4 "conduit or equivalent.
3. Locate earth ground connection to panel grounding bar or to earth ground rod.
4. Locate 24" power cable. When installing the power cable do not use sensor connectors. Uses knock out at different location.
5. Connect ground earth cable from E-25 unit to Customer Sub Panel earth ground rod. Use existing power cable connectors for grounding cable. Ensure all mechanical connector secure and making full contact.
6. For rest of connection follow the Connection type#1 on page 5.

NOTE

All cables are attached to E-25 unit install cables as per local codes and utilize approved IEEE standards and CE Certified components.

Earth ground to be connected for E-25 ground cable to Sub Panel earth ground rod.

All external connections and additional work must be performed by qualified representative in according to state and local codes.

All material used must confirm to the NEC and meet all applicable CE Certified.

Failure to comply will void warranty.

E-25

Field Installation Manual

Model	E-25
Phase Configuration	440V AC 3Phase
Maximum Line Voltage	440V AC
Rating	25 kVar
Monitoring	PF,I,V, kVar, KW
Accuracy	1 kVar
Frequency	50Hz
Protection	3 Pole Circuit Breaker, Capacitor Inbuilt Protection P2
Lighting Strike	Circuit design with clearance and creep age distance/MOVs adequate MOVs not required.
Circuit breaker Required	63 Amp
Low Losses	0.5 Watt per kVar
Dissipation Factor	0.1% at 50 Hz and 25 ^o C
Human Protection	All High voltage shielded from contact.
Operating temperature range	50 ^o C Ambient
Max. Humidity	95% (Non Conditioning)
Dimensions(L X H X D)	20" X 20" X 8.5" Metal Enclosure
Operating Life	Switching tested up to 90,000 times
Wire Gauge & Rating	10 mm ² , 600V
Unit Weight	28 Kg

E-25

Field Installation Manual

Recommended Parts List

	Qty.	Make	Part No.
1. 3/4" watertight connector with seal –tight between sub panel and E-25 with work box.	1		
2. 1/2 watertight connector and appropriate junction box with seal –tight between sub panel and E-25.	1		
3. Wire ties or approved straps for installation current sensor.	---		
4. Current Sensor split core 400 Amp/0.333V AC.	1		
5. 10 mm ² Stranded copper ground cable.	---		
6. Fasteners screw for wall mounting E-25	4		
7. Three pole 60 Amp Breaker or Disconnect Switch for Type 2 & Type 3	1		

All the recommended parts supplied by qualified representative. Company can provide the parts against order.

NOTE

1. Installation of materials and workmanship at the customer's sub panel shall be the responsibility of the qualified Representative in accordance with all state and local codes. Any and all connections exterior to the E-25 unit shall be the responsibility of the qualified representative.
2. **One current sensor for connection only to energy usage monitoring current transformers.**